



# Isobar<sup>®</sup> Heat Pipes

An Isobar<sup>®</sup> Heat Pipe is a super-thermal conductor that has the capacity to transfer large amounts of heat at high speeds in both heating and cooling applications. In fact, Isobar<sup>®</sup> Heat Pipes have, in some applications and orientations, a thermal conductivity in excess of 10,000 times the rate of a solid copper bar of the same geometry. The working fluid constantly changes phase due to the low vapor pressure inside the unit.

The resulting pressure difference moves the vapor from the heated end to colder area where it condenses and releases the heat energy uniformly. Isobars<sup>®</sup> are most successfully used horizontally. Special designs for vertical use are available to order.

Isobars<sup>®</sup> are used instead of conventional water-cooling methods. They can simplify tool design and are easy to fit. They are designed to operate over the range of mold operating temperatures between 35 F and 500 F. For relevant hole dimensions, please see chart below.

Isobar<sup>®</sup> Heat Pipes can be designed or retrofitted into many molding applications to improve efficiency related to cycle times, cure rates, mold temperature uniformity, set-up times and recovery rate. The cooled length should be a minimum of 50% of heated length for maximum efficiency.

DMS can manufacture your core pin and have Isobars<sup>®</sup> charged directly to the core pin.

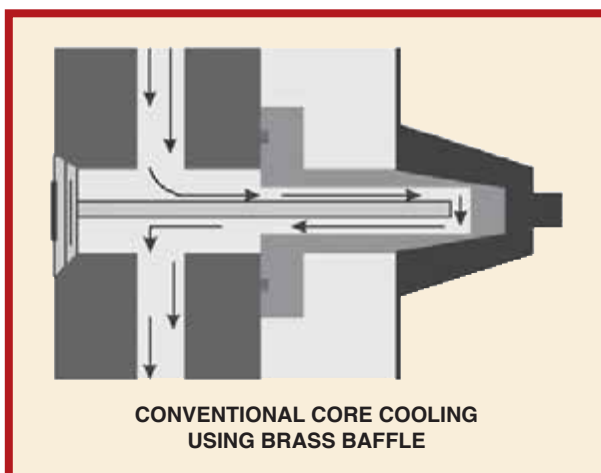
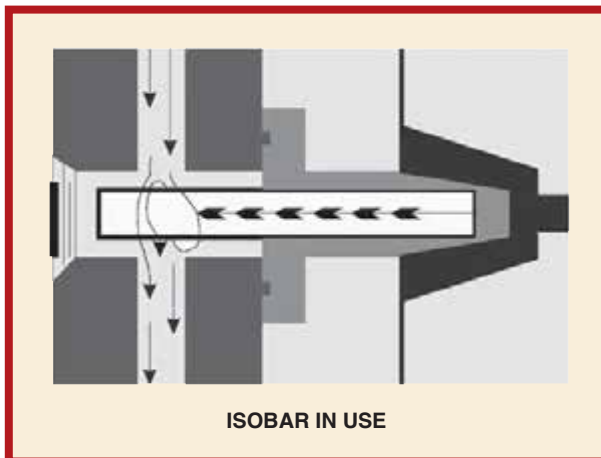
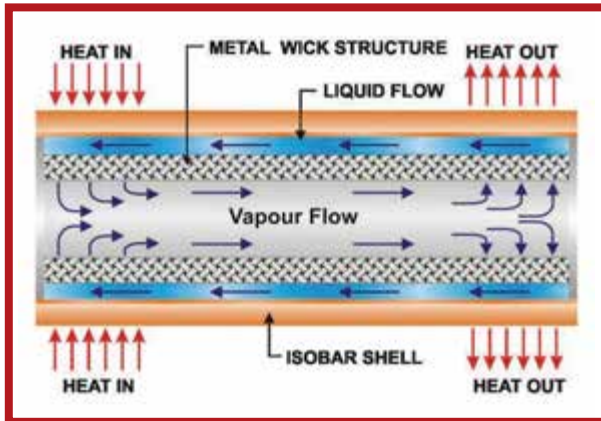

DIAMETER	DRILL (IN.)	TOLERANCE (HIGH)	TOLERANCE (LOW)
3/32	0.096	+0.001	-0.001
1/8	0.127	+0.001	-0.001
5/32	0.157	+0.001	-0.001
3/16	0.189	+0.001	-0.001
7/32	0.219	+0.001	-0.001
1/4	0.252	+0.001	-0.001
5/16	0.314	+0.001	-0.001
3/8	0.377	+0.001	-0.001
1/2	0.502	+0.001	-0.001

DIAMETER	DRILL (mm)	TOLERANCE (HIGH)	TOLERANCE (LOW)
3mm	3.07	+0.03	-0.03
4mm	4.04	+0.03	-0.03
5mm	5.08	+0.03	-0.03
6mm	6.05	+0.03	-0.03
8mm	8.05	+0.03	-0.03
10mm	10.01	+0.03	-0.03
12mm	11.96	+0.03	-0.03
15mm	14.96	+0.03	-0.03
16mm	16.08	+0.03	-0.03
18mm	17.98	+0.03	-0.03
20mm	19.94	+0.03	-0.03
25mm	24.94	+0.03	-0.03
30mm	29.95	+0.03	-0.03



ISOBAR<sup>®</sup> is a registered trademark of Acrolab Ltd.



# Isobar® Heat Pipes



DIAMETER	ISOBAR LENGTH (Isobars can also be manufactured to any length and other diameters)																	
	INCHES	2.0	2.5	3.0	3.5	4.0	4.5	5.0	5.5	6.0	6.5	7.0	7.5	8.0	8.5	9.0	9.5	10.0
3/32																		
1/8																		
5/32																		
3/16																		
7/32																		
1/4																		
5/16																		
3/8																		
1/2																		
MILLIMETERS	50	60	80	100	120	140	160	180	200	220	240	260	280	300	320			
3																		
4																		
5																		
6																		
8																		
10																		
12																		
15																		
16																		
18																		
20																		
25																		
30																		

Length Tolerances: +0.000/-0.060 inches  
+0.00/-1.50 millimeters

Standard sizes come with extractable end caps  
Ordering Information: HP-D X L

Custom sizes also available  
**ISOBARs® MUST NEVER BE CUT.**

### ISOBAR® INSTALLATION PROCEDURE

1. Inspect holes into which Isobars will be inserted to make sure that holes are free of oil or solvent contamination, as well as steel chips or other foreign debris.
2. Ensure that hole ends are deburred so as to cause no interference or galling of the Isobar® surface.
3. Apply a liberal amount of thermal paste over the Isobar's® entire length.
4. Apply a small amount of paste into the hole opening and begin to insert the Isobar® by alternately rotating and pushing the Isobar into the hole and withdrawing it slightly to ensure the entire surface of the Isobar® and the hole opening are coated with paste.
5. Insert the Isobars® (threaded end last) with hand pressure only. Never install an Isobar® by tapping, hammering, or using an excessive amount of force, as this will most often result in damage to the Isobars®.
6. Wipe off excess thermal paste from the tool with a soft cloth; do not use solvents.
7. In the event that the holes drilled for the Isobars® are exposed to the outer surface of the mold, these areas must be covered with a 1/8 inch or 3mm steel plate of suitable rigid insulation in order to completely encapsulate the Isobar® within the tooling confines. This should be done as a safety concern to prevent damage resulting from the possible overheating of the tool in excess of 550 F or 280 C.

**CAUTION: EXPOSURE OF ISOBARs® TO EXCESSIVE TEMPERATURES OR IMPROPER USE MAY CAUSE DAMAGE OR PERSONAL INJURY.**

ISOBAR® is a registered trademark of Acrolab Ltd.

## Thermally Conductive Paste

CATALOG NUMBER	VOLUME
TCP-1	5 GR.
TCP-4	4 OZ.
TCP-8	8 OZ.
TCP-16	16 OZ.

NOTE: Although thermal paste is inert, rubber gloves are recommended to keep hands clean.



www.acrolab.com